

# DH-3

Linkage-type adaptive grippers

DH-ROBOTICS

Gripping force(per jaw)

Opening/closing stroke(both sides)

**10~65 N 106 mm(parallel)**  
**122 mm(centering)**

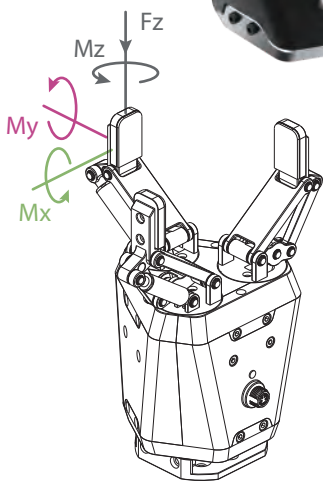

Allowable vertical load (static)

Fz: 300 N

Allowable vertical load (static)

Mx: 2.5 N·m

My: 2 N·m

Mz: 3 N·m

## Mechanical specifications

Maximum recommended load**	1.8 kg
Position repeatability (both sides)	± 0.03 mm
Opening/closing time	0.7 s/0.7 s
Driving method	Screw nut + gear drive + linkage mechanism
Weight	1.68 kg
Noise emission	< 50 dB

## Electrical specifications

Communication interface	Standard: Modbus RTU (RS485), Digital I/O Optional: TCP/IP, USB2.0, CAN2.0A, PROFINET, EtherCAT
Nominal voltage	24 V DC ± 10%
Nominal current	0.5 A
Peak current	1 A
Recommended operating environment	0~40°C, 85% RH under environment

\*取决于抓取物体形状、接触面材料与摩擦力以及运动加速度等因素，抓取物体的重心偏移也会影响到负载，如有问题请咨询我们。

